

Data subject to change without prior notice
Edition 03/2020 © 2020 JMG Cranes S.p.A. All rights reserved
Rev.1 - 03/20



Electric Pick & Carry Cranes

JMG Cranes S.p.A.

Sales & Service Office
Via Bergamo, 142
26100 Cremona - Italy
t +39 0372 1786738
Production Plant
Via Sito Nuovo 14
29010 Sarmato (PC) - Italy
t +39 0523 8486
e info@jmgcranes.com

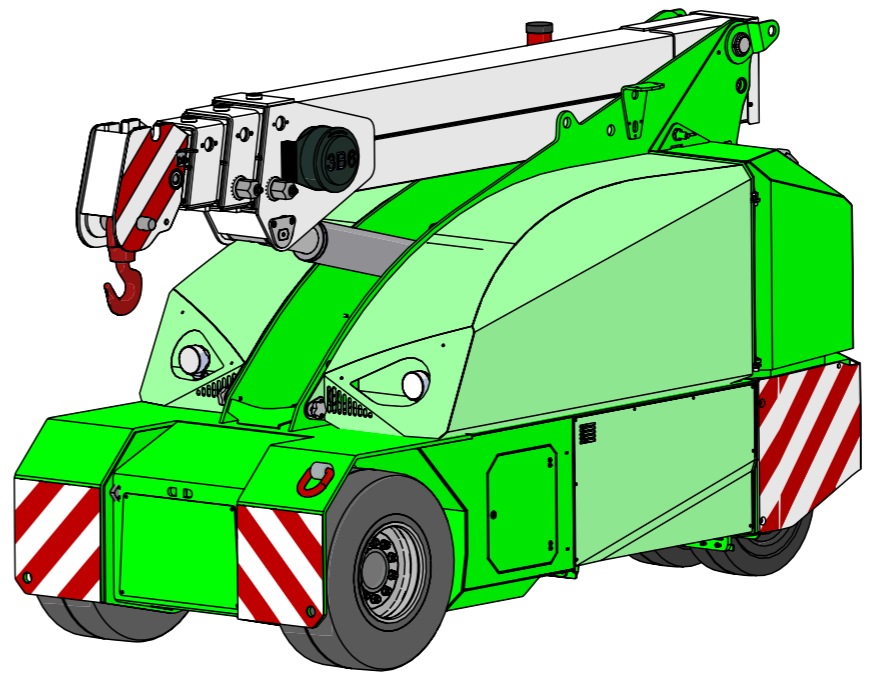

MC 45S (inch)
Max Capacity 10,000 lbs

www.jmgcranes.com



MC 45S

RADIO-REMOTE CONTROL ON DRIVING, STEERING, BOOM MOVEMENTS, WINCH AND OTHER ACCESSORIES

FRONT-WHEELS DRIVE WITH COUNTER ROTATION

REMOVABLE COUNTERWEIGHTS

HYDRAULICALLY TELESCOPING SEQUENTIAL TYPE BOOM

Options :

- HYDRAULIC WINCH
- HYDRAULIC FLY JIB
- BENDABLE MANUAL JIB WITH MANUAL EXTENSION
- NON-MARKING TIRES
- HYDRAULIC FORKS
- MAN BUCKET
- ATEX CONVERSIONS
- CUSTOMIZED PAINTING



Technical features

Max Capacity lbs	10,000
Dimensions inch	9'1"x3'11"x5'5"

Front-wheels drive. 2 electric motors AC 3 kW 48V Insulation class H	LMI. Electronic safe load indicator and tilting moment limiter
Total lbs 11,000 Removable counterweights lbs 3,000	Automatic braking system on all wheels
48 V - 600 Ah 8 working hours	Fabricated from preformed and welded quality steel plate
Front nr. 2 superelastic 23x10-12" Rear nr. 2 superelastic 18x7-8"	+60°-15°
Rear Steering angle -90°/+90°	Motor driven pump 9 kW - 48 V AC, Insulation class H



Load charts

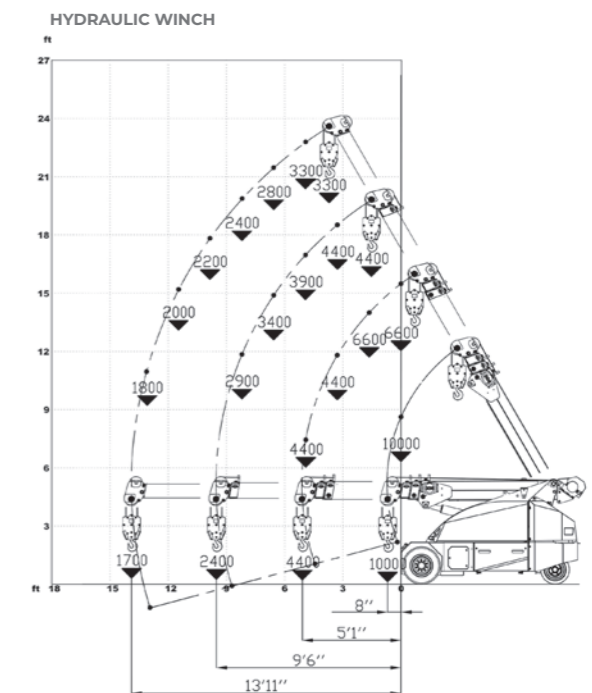
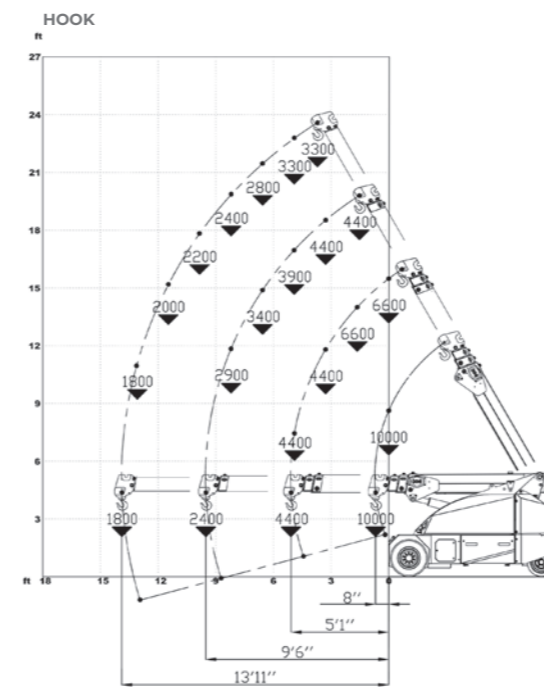

EU Standards CE

	UNI ISO 4030-1: A1
	2006/42/CE- 2000/14/CE -2014/30 UE 2014/35/UE - D.Lgs 262/2002 subsequent modifications
	EN 13000:2014 subsequent modifications



Dimensions

