

Data subject to change without prior notice
Edition 03/2020 © 2020 JMG Cranes S.p.A. All rights reserved
Rev.1 - 03/20

JMG Cranes S.p.A.

Sales & Service Office

Via Bergamo, 142

26100 Cremona - Italy

t +39 0372 1786738

Production Plant

Via Sito Nuovo 14

29010 Sarmato (PC) - Italy

t +39 0523 8486

e info@jmgcranes.com



Electric Pick & Carry Cranes



**MC25S
(inch)**
Max Capacity 5,500 lbs

www.jmgcranes.com



MC 25S

SEQUENTIAL TELESCOPING BOOM

FRONT-WHEELS DRIVE WITH COUNTER ROTATION

TILTING HEAD 4 POSITIONS (-70°/-35°/0°/+10°)

REMOVABLE COUNTERWEIGHT

USB PLUG

BLOCKS AND HOOKS LODGING ON BOARD

Optionals:

- HYDRAULIC WINCH
- BENDABLE MANUAL EXTENSION
- NON-MARKING TIRES
- MAN BUCKET
- ATEX CONVERSIONS
- CUSTOMIZED PAINTING
- TOOL BOX



Technical features

Max Capacity lbs	5,500
Dimensions inch	7'2"x2'11"x5'33"

Front-wheels drive. 2 electric motors AC 2 kW 24V Insulation class H	LMI. Electronic safe load indicator and tilting moment limiter
Total lbs 5,300 Removable counterweight lbs 1,650	Automatic braking system on all wheels
24 V - 420 Ah 8 working hours	Fabricated from preformed and welded quality steel plate
Front nr. 2 superelastic 18x7-8" Rear nr. 2 superelastic 15x4 1/2-8"	+65°/-15°
Rear Steering angle -90°/+90°	Motor driven pump 3 kW - 24 V AC, Insulation class H

Load charts

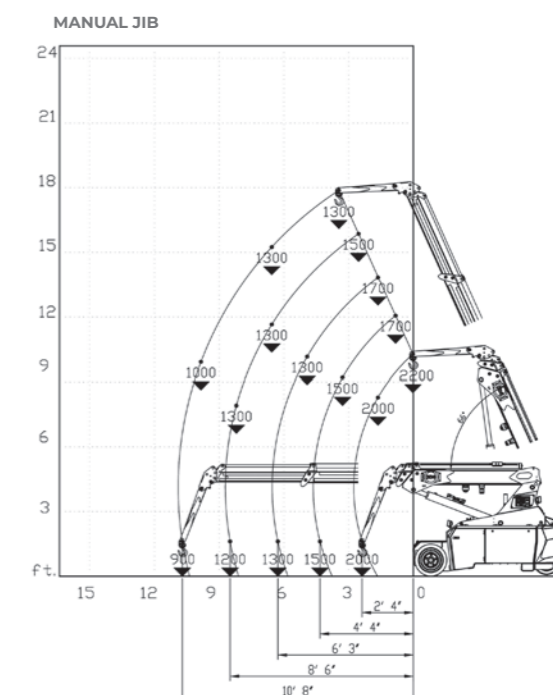
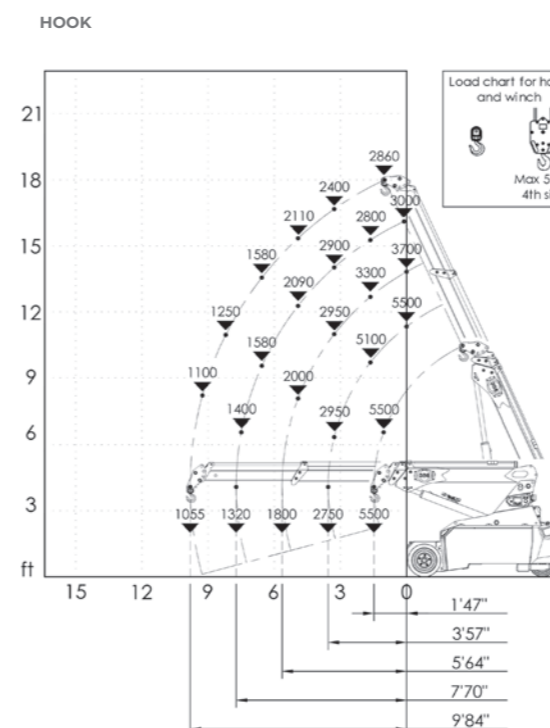

EU Standards CE

	UNI ISO 4030-1: A1
	2006/42/CE- 2000/14/CE -2014/30 UE 2014/35/UE - D.Lgs 262/2002 subsequent modifications
	EN 13000:2014 subsequent modifications



Dimensions

